

StormBasin



The StormBasin catch basin insert combines a gross pollutant trap with Fabco's proprietary cartridge filtration system for effective capture of both solid and soluble pollutants. Fabco filter cartridges can be customized with specific media that can target fine particulate, hydrocarbons, heavy metals, organics and other pollutants.

Ideally suited for municipal storm drain retrofits, the StormBasin's solid construction and unique design allow for easy installation and maintenance. The StormBasin also features Fabco's patented dovetailed aluminum flange which enables quick sizing adjustments during installation. Fabco filter cartridges feature a twist and lock mechanism that

makes replacement fast and simple. Periodic maintenance of the StormBasin is quick and easy - trash and debris can be removed from the unit at the street level with a vactor truck or a vacuum hose attached to a sweeper truck. Extracted waste has minimal water content reducing disposal weight and volume.

Fabco's StormPod offers the same filtration method, but for smaller, round openings.

Features/Benefits

1. Easily replaceable lightweight filter cartridges customized for targeted pollutants
2. Durable, UV safe co-polymer basin with aluminum mounting flange - has a 15 year service life
3. Patented dovetailed flange allows for 5" of length/width adjustment during installation
4. Baffled bypass traps floatables

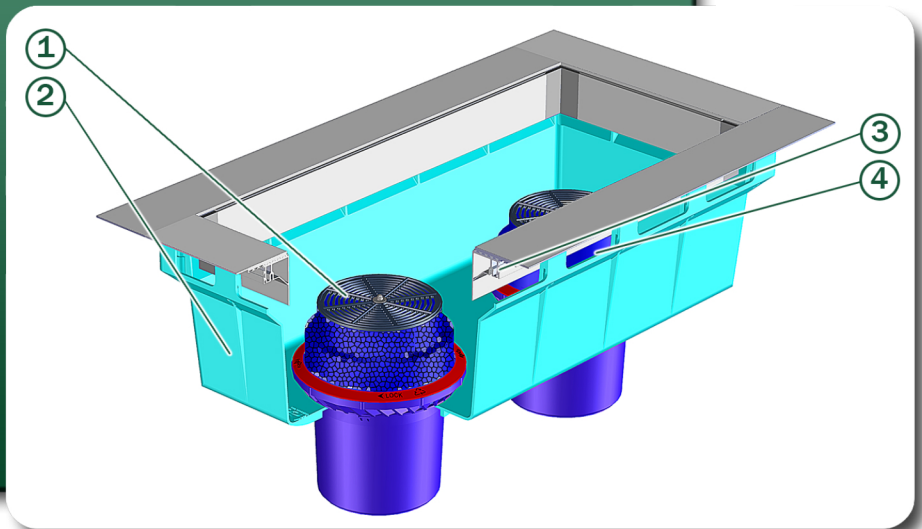

| Application | Regulatory Issue | Target Pollutants |
|--|--|---------------------------------|
| Municipal Storm Drain Retrofits | MS4 Permit | Sediment, Trash, O&G, Nutrients |
| Fuel/Oil Storage and Handling Facilities | EPA SPCC (Spill Control Rule) | Hydrocarbons, Oily Sediments |
| Scrap Metal, Solid Waste, Power Plants | Industrial Multi-Sector General Permit | Solids, Hydrocarbons, Metals |
| Pre-Treatment BMP for New Development | Municipal Stormwater Permit | Sediment, O&G, Nutrients |
| Retail, Garden Centers | Phosphorus, Nitrogen, Pesticides | Fertilizers, Pesticides |